



Version
02.00

May
2007

R&S®FSUP Signal Source Analyzer

Phase noise tester and high-end spectrum analyzer in a single box

- ◆ Frequency range up to 8/26.5/50 GHz
- ◆ Up to 110 GHz with external mixers
- ◆ Maximum flexibility in phase noise measurements:
 - Phase detector method
 - Internal/external reference
 - Phase detector method with cross-correlation
 - Spectrum analyzer method
- ◆ Complete characterization of oscillators:
 - Phase noise
 - Characteristics
 - Transient response
 - Harmonics
- ◆ Fast and easy operation
- ◆ Maximum sensitivity in phase noise measurements (e.g. at 1 GHz input frequency):
 - 134 dBc (1 Hz) at 10 kHz offset
 - 165 dBc (1 Hz) at 10 MHz offset
- ◆ Unrivaled dynamic range:
 - TOI typ. +25 dBm
 - DANL: –160 dBm



ROHDE & SCHWARZ

R&S®FSUP +++ Phase noise tester +++ time domain ana

One of the primary tasks in developing transmit and receive modules is to measure oscillator phase noise. This is necessary not only in the development and production of state-of-the-art communications and broadcast systems but also in special high-tech applications such as radar. Measuring phase noise is especially difficult and costly when it comes to high-quality oscillators.

But phase noise is only one of the factors that need to be measured when characterizing oscillators. Others include tuning slope, transient response, power, harmonics, and spurious emissions.

You can perform all these measurements with the R&S®FSUP, the only signal source analyzer covering the frequencies up to the microwave range in a single box. The R&S®FSUP combines the functionality of the high-end R&S®FSU spectrum analyzer with the advantages of a pure phase noise tester with very low-noise DC sources, thus enabling you to perform a wide range of measurements. For example, you can measure the phase noise of VCOs, DROs, or XCOs, plus determine harmonics and spurious emissions.

- ◆ Phase noise measurement with phase detector method up to a frequency offset of 30 MHz:
 - With internal reference
 - With external reference
- ◆ Direct phase noise measurement with the spectrum analyzer
- ◆ Characteristic oscillator parameters
 - Tuning characteristic with constant and variable supply voltage
 - Tuning slope
 - Output power versus frequency and supply voltage
 - Spurious emissions and harmonics
 - Transient response of synthesizers



alyzer +++ spectrum analyzer

Moreover, the R&S®FSUP offers a very simple and straightforward operating concept. You can quickly start even the most sophisticated measurements with only a few keystrokes. The wiring used in your specific measurement method is graphically displayed. Front-panel LEDs provide additional help. Measuring phase noise, generally a very complex task with high-quality oscillators, thus becomes extremely simple. The R&S®FSUP enables even untrained engineers to obtain results quickly.

Complete characterization of oscillators

Low-noise source for supply and tuning voltage

Before you can record characteristics and measure phase noise by using the phase comparator method, you have to make extensive supply and tuning voltage settings on the oscillator. The R&S®FSUP provides two independent, extremely low-noise DC outputs for this purpose. You can define the supply and tuning voltage for each output. An easy-to-use menu enables you to set the voltages for the individual ports. Depending on the measurement, you can modify the values to reflect the settings without violating the minimum and maximum values.

You can also define the order in which the various voltages are added after the measurement is started. A negative voltage supply is provided for special applications.

DC outputs	
Voltage	0 V to 12 V
Measurement accuracy	<0.4%
Noise	10 nV/Hz at 10 kHz
Max. current	500 mA
Tuning outputs	
Voltage	-10 V to +28 V
Measurement accuracy	<0.2%
Max. current	20 mA
Noise	1 nV/Hz at 10 kHz

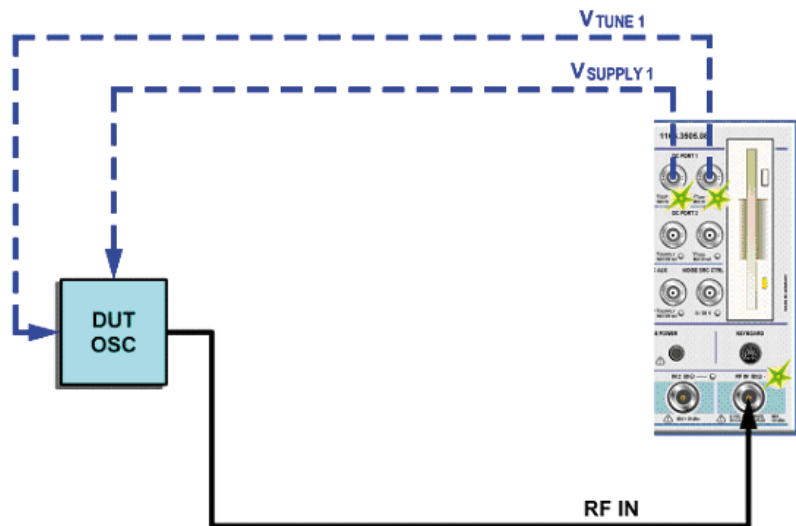

The wiring of the test setup for a specific measurement method is displayed – front-panel LEDs offer additional help.

R&S®FSUP +++ Phase noise tester +++ time domain ana

Measurement applications with phase comparator

In this mode, the R&S®FSUP allows you to make various settings for phase noise measurements. The most commonly used mode – measurement by means of the internal phase comparator using an internal reference – is predefined. Since many applications call for an enhanced test setup, the R&S®FSUP provides a convenient menu for quickly setting various measurement modes.

When using premium oscillators with very good phase noise characteristics, the oscillators are commonly measured against one another and the result is then adjusted by 3 dB – a measurement that can directly be carried out with the R&S®FSUP.

Even if your application requires a complex test setup, e.g. with an external reference and external downconverter, the R&S®FSUP can easily meet the challenge, including helpful schematics.



Easy setting of test setup in configuration menu with display of recommended measurement range.

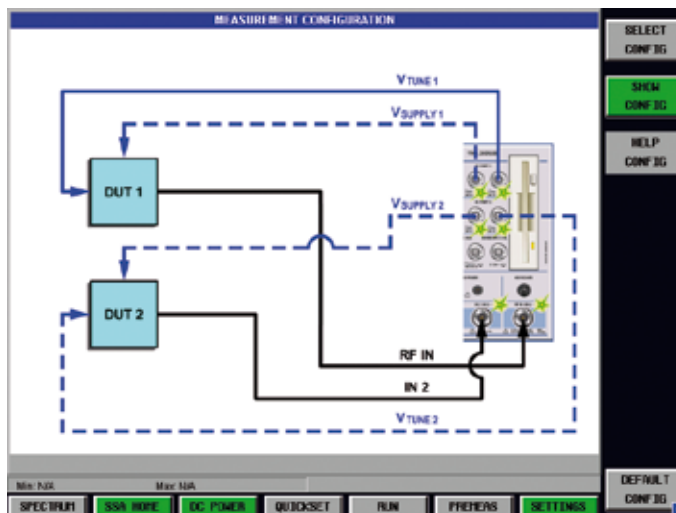

Measurement carried out on two identical oscillators. The final result is corrected by 3 dB.

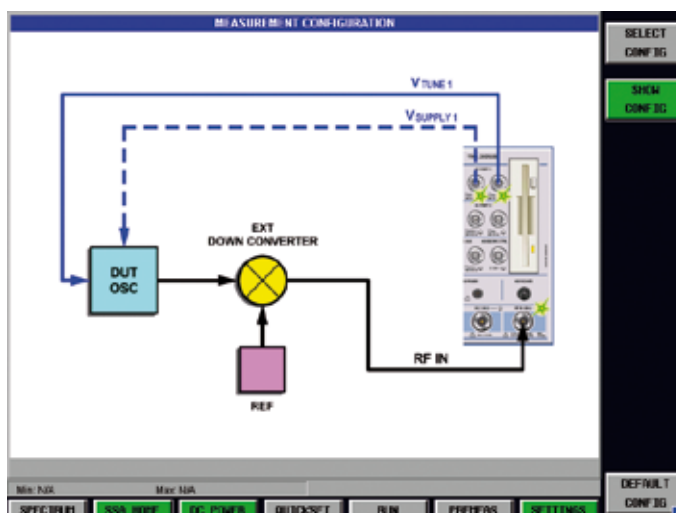

Test setup with external downconverter.

analyzer +++ spectrum analyzer

Quick and easy presetting of key parameters

All important oscillator parameters such as power and tuning slope are measured automatically in order to generate stable settings for the phase-locked loop (PLL). In addition, the loop bandwidth and IF gain are set automatically. Depending on the input frequency, the R&S®FSUP uses internal frequency multipliers to operate the internal reference in the optimum range. All automatically set parameters can be modified and adapted to specific measurement applications.



Clear definition of measurement range, bandwidths, and averaging

Together with other measurement parameters such as bandwidth, type of filter, and number of averages, you can quickly and easily set the offset frequency range for the phase noise measurement via a straightforward menu. The menu layout is similar to that of the R&S®FS-K40 application firmware for phase noise measurements. This makes operation very easy, including switching between the various measurement modes. Predefined settings for fast and highly stable measurements also facilitate operation.

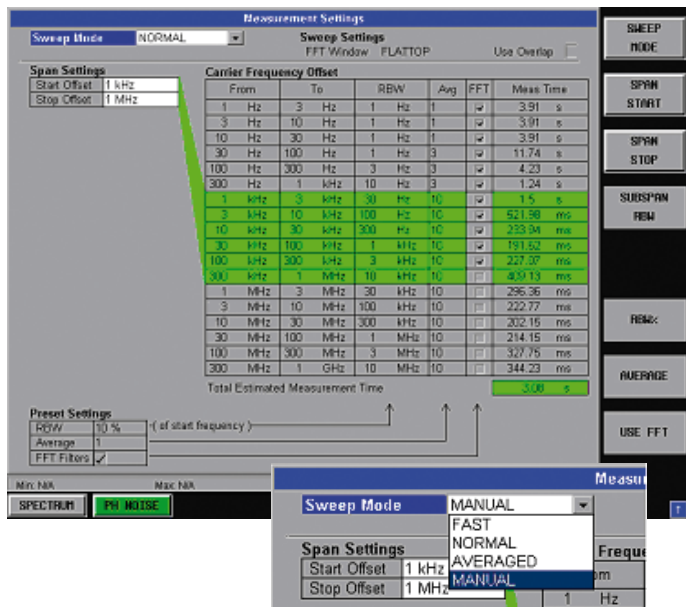

R&S®FSUP +++ Phase noise tester +++ time domain ana

Convenient phase noise measurement

After the start of the phase noise measurement, LOCKED or UNLOCKED will be displayed to indicate whether the PLL is locked and whether a successful measurement can be started. The loop bandwidth used and the voltage on the phase detector are displayed during the measurement. By using a complex algorithm, you can eliminate by calculation, list, and suppress all interference (for example caused by hum) or specific, clearly defined interference.

When the "highlight spurs" function is enabled, interference can also be displayed as vertical lines instead of imaging of the frequency response of the resolution filter used during phase noise measurement. This makes the identification of spurious much easier. The level is output in dBc or in dBc/Hz.

Limit lines are not only available for the measured phase noise but also for spurious. This allows you to decide whether to check phase noise, spurious level or both when performing a VCO test.

You can display integral parameters such as residual FM/ϕM or RMS jitter, where the complete measurement range is used to calculate them. Moreover, you can define the integration limits yourself.



Typical phase noise measurement with phase detector method – signal frequency, level, and residual noise are displayed.



Interference can be identified (vertical blue lines) and listed.



Interference can be suppressed to obtain a spurious free measurement trace for documentation.

analyzer +++ spectrum analyzer

Exceptional sensitivity in phase noise measurements

To ensure reliable oscillator measurements, the internal reference must exhibit negligible phase noise when compared with the oscillator. To achieve this, the R&S®FSUP has an internal source with exceptional phase noise values, e.g. at an input frequency of 1 GHz:

- ◆ -134 dBc (1 Hz) at 10 kHz frequency offset
- ◆ -165 dBc (1 Hz) at 10 MHz frequency offset

Cross-correlation to reduce phase noise

The R&S®FSUP-B60 option provides the R&S®FSUP signal source analyzer with two parallel receive paths. You can perform cross-correlation between the two paths owing to the symmetrical structure, and eliminate the uncorrelated inherent noise of the two reference sources. This method can be used in the range from 10 MHz to 8 GHz. Sensitivity is thus significantly increased and no longer limited by the phase noise of the internal references. The degree of improvement depends on the number of averages and can be up to 20 dB.

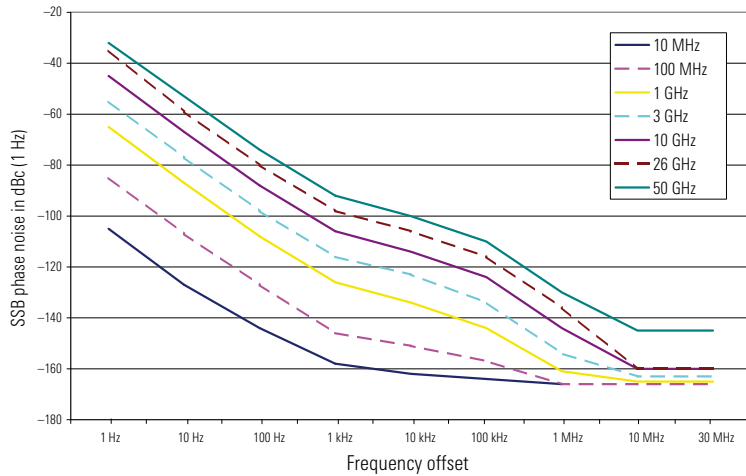

Phase noise of internal reference source for different input frequencies.



Improvement of phase noise sensitivity achieved by means of cross-correlation. A phase noise measurement is shown without cross-correlation (yellow trace) and with cross-correlation (100 and 1000 averages).

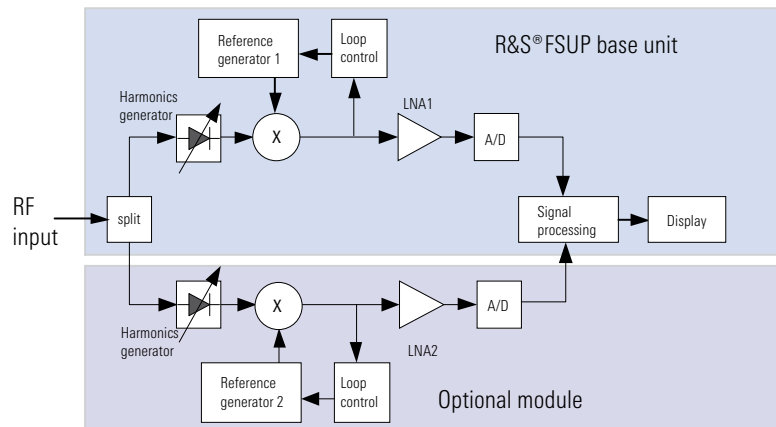

Cross-correlation – two identical receive paths allow you to minimize the impact of the internal reference.

R&S®FSUP +++ Phase noise tester +++ time domain ana

Measurement of phase noise using the spectrum analyzer method

Since the R&S®FSUP signal source analyzer is a high-end spectrum analyzer as well, you can also measure the phase noise directly in the spectrum. This measurement is more time-consuming and less sensitive but enables you to measure frequency offsets that are significantly higher. Inherent noise of the system can be subtracted after a reference measurement.



Measurement of phase noise using the spectrum analyzer method. The blue trace shows the measurement result up to an offset frequency of 1 GHz, the inherent noise of the system (green trace) is subtracted from the original measurement (yellow trace).

Indispensable spectrum analyzer functions

In addition to the normal scope of functions, the R&S®FSUP offers highly useful additional measurement capabilities for VCO characterization such as the spurious emissions measurement function, already available on the R&S®FSU spectrum analyzer. You can define different sweep ranges including special parameters in a list. The analyzer then automatically searches for interference in these sweep ranges. Up to 100 000 measurement points are evaluated, and the result is displayed in a peak list.

SWEEP LIST					
	Range 1	Range 2	Range 3	Range 4	Range 5
Range Start	150 kHz	50 MHz	150 MHz	2 GHz	
Range Stop	30 MHz	150 MHz	2 GHz	8 GHz	
Filter Type	NORMAL	NORMAL	NORMAL	NORMAL	
RBW	10 kHz	50 kHz	100 kHz	1 MHz	
VBW	30 kHz	200 kHz	300 kHz	3 MHz	
Sweep time mode	AUTO	AUTO	AUTO	AUTO	
Sweep time	300 ms	60 ms	100 ms	120 ms	
Detector	MAX PEAK				
REF-Level	-40 dBm				
RF-Att. mode	MANUAL				
RF-Attenuator	0 dB				
PRE-AMP	OFF				
Sweep Points	10000				
Stop after sweep	ON				
Transd. factor	<NONE>				

GUEST PEAK LIST				
TRACE / DETECTOR	FREQUENCY	LEVEL dBm	DELTA LIMIT dB	
1 Maxpeak	935.2016 MHz	-61.59	200.00	
1 Maxpeak	935.6950 MHz	-82.65	200.00	
1 Maxpeak	936.1883 MHz	-71.68	200.00	
1 Maxpeak	936.5583 MHz	-79.65	200.00	
1 Maxpeak	937.1750 MHz	-77.13	200.00	
1 Maxpeak	936.0363 MHz	-77.63	200.00	
1 Maxpeak	939.3950 MHz	-80.86	200.00	
1 Maxpeak	939.9500 MHz	-83.42	200.00	
1 Maxpeak	940.8133 MHz	-64.92	200.00	
1 Maxpeak	941.0600 MHz	-72.67	200.00	
1 Maxpeak	941.1833 MHz	-65.09	200.00	
1 Maxpeak	941.8000 MHz	-83.79	200.00	

Sweep list for defining the measurement and peak list for result display.

Another important function for characterizing signal sources is the measurement of the adjacent-channel power (ACP). In this case as well, the R&S®FSUP offers convenient measurement functions already provided by the R&S®FSU spectrum analyzer. Predefined standard settings are available. You can also define channel widths and channel spacing and select the parameters with a large degree of flexibility. The unrivaled dynamic range of the R&S®FSUP clearly sets new standards for signal source analysis.

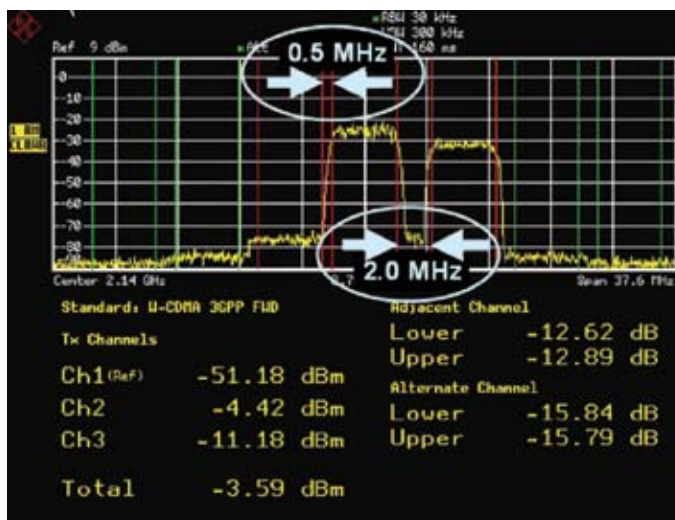

The spectrum analyzer mode provides a convenient ACP measurement function, which also allows highly flexible definition of channel width and channel spacing.

alyzer +++ spectrum analyzer

Analysis in the time domain

The R&S®FSUP can record the oscillator signal as a function of time and thus display settling and switching times at high-frequency broadband sources. Thus, the R&S®FSUP can do more than just measure the phase noise and the spectrum. It can also precisely analyze the signal source behavior in the time domain.

Optimum product solution

The clear speed advantage of the phase comparator method in phase noise measurements over direct measurements using the spectrum analyzer makes the R&S®FSUP the ideal instrument for phase noise measurements at production sites. Since the phase noise tester and spectrum analyzer are combined in a single box, investments at production facilities are clearly lower, test setups become more straightforward, and flexibility increases. Of course, all R&S®FSUP functions can be remote-controlled via LAN or GPIB, allowing easy integration in production lines.

Removable hard disk

To meet the security requirements of classified areas, a removable hard disk is available for the R&S®FSUP. In addition, the removable hard disk drive is more reliable at higher temperatures.



Transient response of a generator.

R&S® FSUP +++ Phase noise tester +++ time domain analysis

Characteristics at a keystroke

You can primarily perform the following three measurements, where you are allowed to define the number of measurement points:

- ◆ Tuning characteristic:
The tuning voltage is modified at a constant supply voltage
- ◆ DC dependencies:
The supply voltage is modified at a constant tuning voltage
- ◆ The combination of both (pushing)

Characteristic parameters can be measured not only for the fundamental but also for harmonics. You can select the tuning voltage or the frequency for scaling the x-axis. And you can define the measurement procedure, the trace display, the number of harmonics, etc. in a straightforward menu. All results can also be displayed in a table.

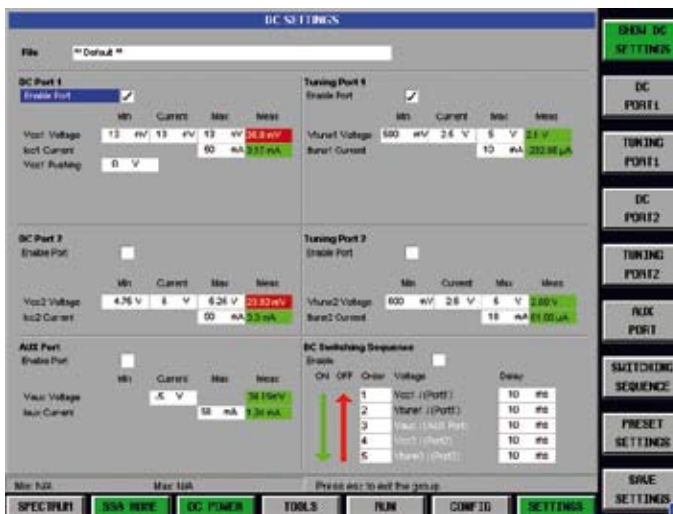

Menu for setting the DC ports for signal source analysis and additional port for negative supply voltage.



All important VCO parameters in one table.

VCO tuning characteristic

The tuning voltage of the oscillator varies within the limits defined when the DC settings for the individual port were made. The result shows the settable frequency range and the tuning slope of the oscillator in graphical form.

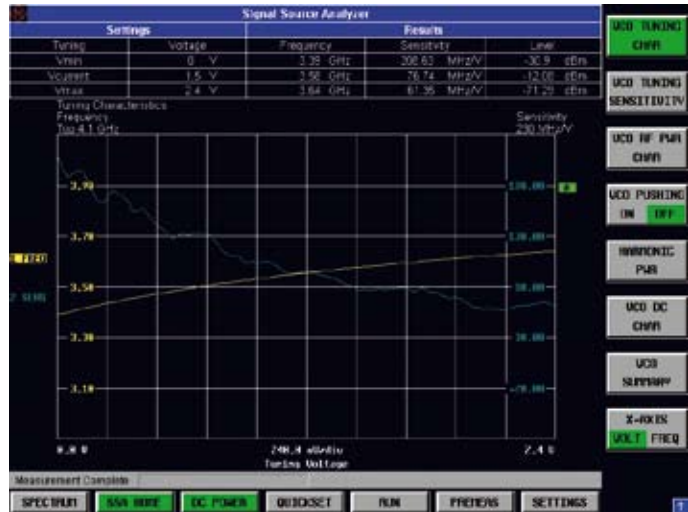

VCO tuning sensitivity

Displays the tuning slope versus the measured frequency range or the tuning voltage. Also the output power is displayed.



VCO RF power characteristic

Displays the output power of the signal source and the oscillator frequency as a function of the tuning voltage.

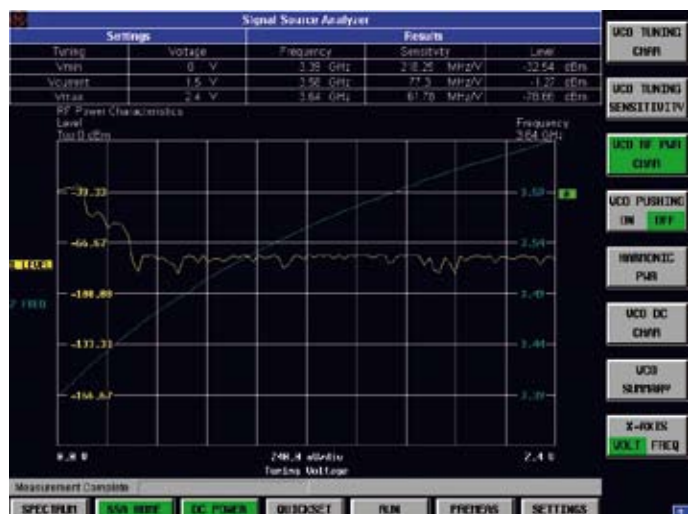

R&S® FSUP +++ Phase noise tester +++ time domain analysis

VCO pushing

This measurement method examines the impact of the supply voltage on the frequency and power of the signal source. The screenshot shows the tuning characteristic of a VCO as a function of the input voltage.

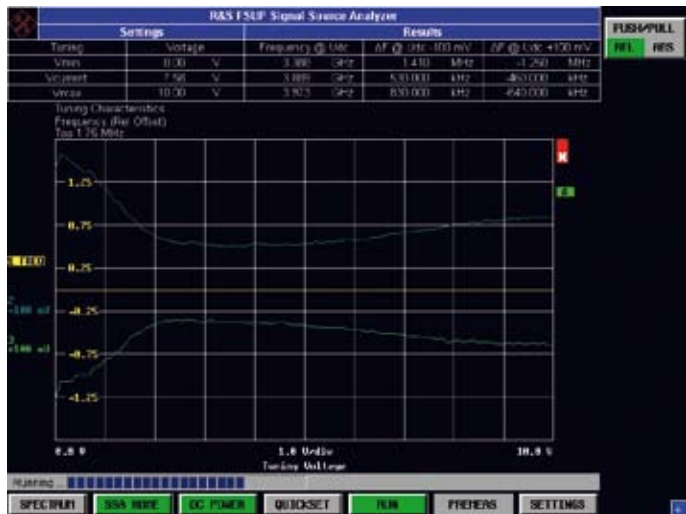

Harmonic power

Displays the power of up to three harmonics at different tuning voltages.

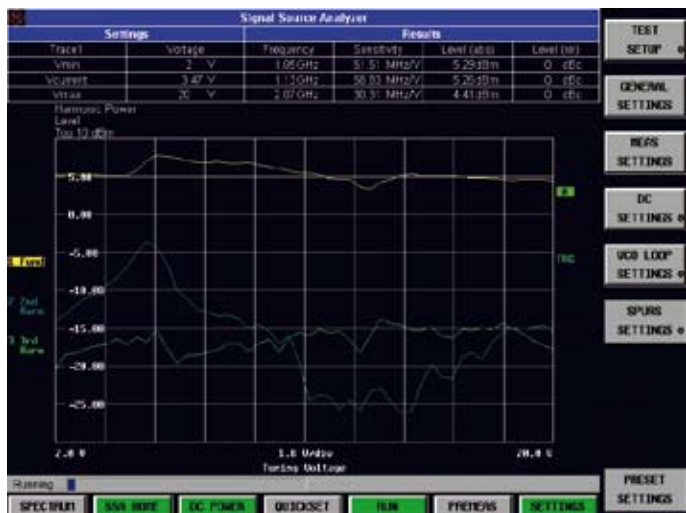

VCO DC characteristic

Measures how the frequency and power vary as a function of the supply voltage when the tuning voltage is held constant.



analyzer +++ spectrum analyzer

Signal Analysis of Mobile Communication Standards – from GSM ...

In conjunction with the R&S®FS-K5 GSM/EDGE application firmware, the R&S®FSUP offers complete functionality for RF and modulation measurements in GSM systems. EDGE (generation 2.5) is already included in the R&S®FS-K5 option.

- ◆ Phase/frequency error for GSM
- ◆ Modulation accuracy for EDGE with:
 - EVM and ETSI-conforming weighting filters
 - OOS
 - 95:th percentile
 - Power versus time with synchronization to midamble
 - Spectrum due to modulation
 - Spectrum due to transients

... to UMTS

In conjunction with the R&S®FS-K7x application firmware, standard 3GPP modulation and code domain power measurements can be performed

- ◆ Additional measurement functions in line with 3GPP specifications for FDD and TDD LCR modes
- ◆ High measurement speed of 1 s/measurement for 3GPP BTS signals
- ◆ Code domain and CPICH power
- ◆ Code domain power and rho (CDMA2000®/3GPP2)
- ◆ EVM and PCDE
- ◆ Code domain power versus slot
- ◆ EVM/code channel
- ◆ Spectrum emission mask
- ◆ Constellation (symbol, composite)

Measurement of modulation spectrum on EDGE burst.

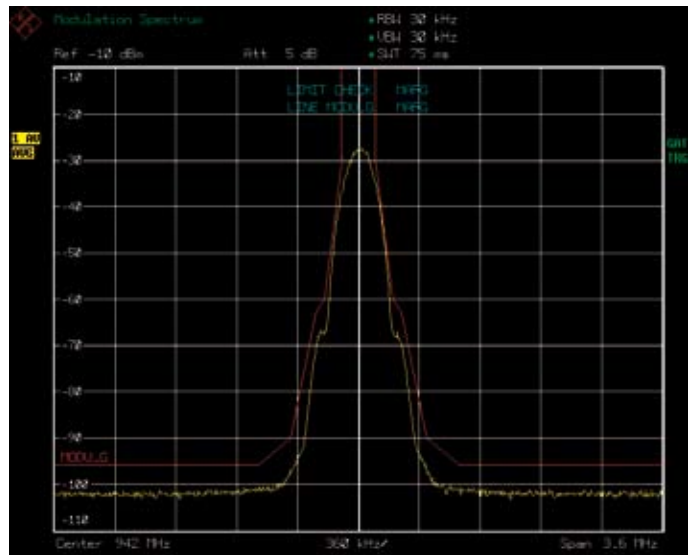

Measurement of modulation accuracy on EDGE burst.

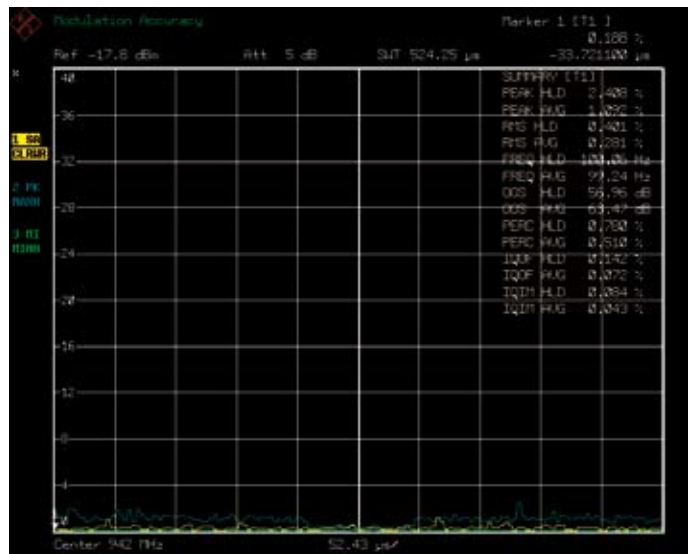

WCDMA code domain power measurement with the R&S®FSQ and R&S®FS-K72/R&S®FS-K74 (HSDPA).

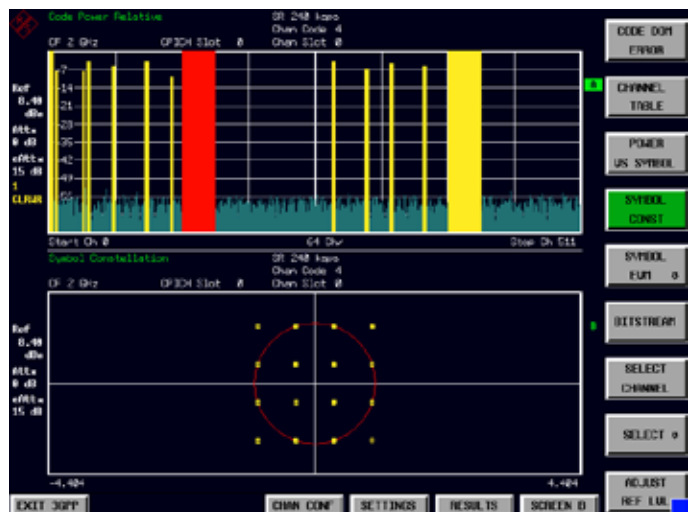

R&S® FSUP +++ Phase noise tester +++ time domain analyzer

Condensed data

Operating modes	signal source analyzer	10 MHz to 8/26.5/50 GHz
	spectrum analyzer	20 Hz to 8/26.5/50 GHz
Signal source analyzer	phase noise measurement with spectrum analyzer	20 Hz to 8/26.5/50 GHz
	phase noise measurement with phase comparator	10 MHz to 8/26.5/50 GHz
	internal reference	10 MHz to 8/26.5/50 GHz
	external reference	10 MHz to 8 GHz
	phase noise measurement with phase comparator and cross-correlation	10 MHz to 8 GHz
	transients measurement	
	VCO parameter characterization	20 Hz to 8/26.5/50 GHz
	min. frequency offset	1 Hz
max. frequency offset	30 MHz	

Sensitivity

With internal reference oscillator and phase detector (typical values in dBc).

Input level >+5 dBm (with R&S®FSUP-B60 option >+10 dB), harmonic auto selected, +20 °C to +30 °C.

LNA gain 30 dB, loop bandwidth $\leq 10 \times$ frequency offset, max. 10 kHz.

Frequency offset								
	Input frequency							
	10 MHz	100 MHz	1 GHz	3 GHz	10 GHz	18 GHz	26 GHz	50 GHz
1 Hz	-105	-85	-65	-55	-45	-40	-35	-32
10 Hz	-127	-107	-87	-77	-67	-62	-59	-53
100 Hz	-144	-127	-108	-98	-88	-83	-80	-74
1 kHz	-158	-146	-126	-116	-106	-101	-98	-92
10 kHz	-162	-151	-134	-123	-114	-109	-106	-100
100 kHz	-164	-157	-144	-134	-124	-119	-119	-110
1 MHz	-166	-166	-161	-154	-144	-139	-136	-130
10 MHz	-	-166	-165	-163	-160	-160	-160	-145
30 MHz	-	-166	-165	-163	-160	-160	-160	-145

VCO parameter characterization		
Measurement parameters	VCO tuning characteristic, VCO tuning slope, power, pushing ON/OFF, measurement of harmonics, VCO DC characteristic, summary	
Frequency range	R&S®FSUP 8	20 Hz to 8 GHz
	R&S®FSUP 26	20 Hz to 26.5 GHz
	R&S®FSUP 50	20 Hz to 50 GHz
Power supplies	tuning ports	2
	DC ports	2
	additional ports	1

alyzer +++ spectrum analyzer

Ordering information

Order designation	Type	Order No.
Signal Source Analyzer 20 Hz to 8 GHz	R&S®FSUP 8	1166.3505.08
Signal Source Analyzer 20 Hz to 26.5 GHz	R&S®FSUP 26	1166.3505.26
Signal Source Analyzer 20 Hz to 50 GHz	R&S®FSUP 50	1166.3505.50
Supplied accessories:		
RF cable, 1 m (1130.1725.00)		
R&S®FSUP 26: test port adapter with 3.5 mm female connector (1021.0512.00) and N female connector (1021.0535.00)		
R&S®FSUP 50: test port adapter with 2.4 mm female connector (1088.1627.02) and N female connector (1036.4777.00)		

Options

Order designation	Type	Order No.	Retrofit	Remarks
Options				
Low-Aging OXCO	R&S®FSU-B4	1144.9000.02	yes	
External Generator Control	R&S®FSP-B10	1129.7246.02	yes	
LO/IF Ports for External Mixers	R&S®FSU-B21	1157.1090.02	no	for R&S®FSUP 26 and R&S®FSUP 50 only
20 dB Preamplifier, 3.6 GHz to 26.5 GHz, for R&S®FSU26	R&S®FSU-B23	1157.0907.02	no	for R&S®FSUP 26 only, requires R&S®FSU-B25
Electronic Attenuator, 0 dB to 30 dB, and 20 dB Preamplifier (3.6 GHz)	R&S®FSU-B25	1044.9298.02	yes	
Trigger Port	R&S®FSU-B28	1162.9915.02	yes	
Removable Hard Disk	R&S®FSUP-B18	1145.0242.07	no	
Second Hard Disk for R&S®FSU-B18	R&S®FSUP-B19	1145.0394.07		requires R&S®FSU-B18
Low Phase Noise Option	R&S®FSUP-B60	1169.5544.02	yes	
Firmware/software				
GSM/EDGE Application Firmware	R&S®FS-K5	1141.1496.02		
AM/FM/ϕM/Measurement Demodulator	R&S®FS-K7	1141.1796.02		
Application Firmware for Bluetooth® Measurements	R&S®FS-K8	1157.2568.02		
Power Sensor Measurements	R&S®FS-K9	1157.3006.02		
Application Firmware for Noise Figure and Gain Measurements	R&S®FS-K30	1300.6508.02		preamplifier recommended (e.g. R&S®FSU-B25)
3 GPP BTS/Node B FDD Application Firmware	R&S®FS-K72	1154.7000.02		
3 GPP UE FDD Application Firmware	R&S®FS-K73	1154.7252.02		
3 GPP HSDPA BTS Application Firmware	R&S®FS-K74	1300.7156.02		
3GPP TD-SCDMA BTS Application Firmware	R&S®FS-K76	1300.7291.02		
3GPP TD-SCDMA MS Application Firmware	R&S®FS-K77	1300.8100.02		
CDMA2000®/1xEV-DV BTS Application Firmware	R&S®FS-K82	1157.2316.02		
CDMA2000®/1xEV-DV MS Application Firmware	R&S®FS-K83	1157.2416.02		
CDMA2000®/1xEV-DO BTS Application Firmware	R&S®FS-K84	1157.2851.02		
CDMA2000®/1xEV-DO UE FDD Application Firmware	R&S®FS-K85	1300.6689.02		

CDMA2000® is a registered trademark of the Telecommunications Industry Association (TIA -USA).

The Bluetooth® word mark and logos are owned by the Bluetooth SIG, Inc. and any use of such marks by Rohde&Schwarz is under license.

Additional information

R&S®FSU Spectrum Analyzer, product brochure PD 0758.0016.12

R&S®FSU Spectrum Analyzer, data sheet PD 0758.0016.22



For specifications, see PD 5213.6729.22
and www.rohde-schwarz.com
(search term: FSUP)



www.rohde-schwarz.com

Europe: +49 1805 12 4242, customersupport@rohde-schwarz.com
USA and Canada: +1-888-837-8772, customer.support@rsa.rohde-schwarz.com
Asia: +65 65 130 488, customersupport.asia@rohde-schwarz.com